

RP Series Regulator Pilot Instruction Manual



Applicable Models:

This Instruction Manual applies to the following VRG RP Series Regulator Pilots. To confirm suitability for additional models and/or components, please contact VRG Controls or view us online at www.vrgcontrols.com

RP-225-SN-CS

RP-700-SN-OS
RP-700-SN-CS
RP-700-SN-CS-HP

RP-1500-SN-CS

STAY IN TOUCH!

Scan the QR Code at right
for company information
and product updates.



ADDRESS: VRG Controls, LLC.
1199-B Flex Court
Lake Zurich, IL 60047, USA
TOLL FREE: (800) 844-FLOW-VRG
E-MAIL: sales@vrgcontrols.com
WEBSITE: vrgcontrols.com

Table of Contents

Description	Page
Scope of Manual & Technical Assistance	3
Product Description	4
Installation	5
Maintenance	6
Technical Specifications	7
Model Numbers	8
Control Spring Specifications	9
Flow Calculations	10
T-block Explanation	11
Normally Open / Normally Closed Explanation	11
Available Models	12-14
Repair Kits	15-17
Factory Quality Checklist	18
Application Schematics	19-24

Scope of Manual:

This Instruction Manual provides instructions for installation, maintenance, adjustment and troubleshooting of VRG Controls **RP Series Regulator Pilots**. This product is typically utilized in conjunction with pilot-operated regulators and a variety of other ancillary devices and accessories. For information on products other than those manufactured by VRG Controls, please consult the appropriate manufacturer.



Warning:



RP Series Regulator Pilots utilize high pressure flammable natural gas or other pneumatic supply as part of their standard operation. Improper installation, operation, maintenance and adjustment of these devices can result in property damage, personal injury or death. Only those qualified through training should install, operate, maintain or adjust this product. Contact your local VRG Controls sales representative or VRG Controls direct for additional information or assistance.

Technical Assistance:

For technical assistance with VRG products, please contact your local VRG Controls sales representative or VRG Controls direct. In order to facilitate technical assistance, we strongly recommend that obtain the MODEL NUMBER and SERIAL NUMBER of the product for which you require assistance prior to contact us. MODEL NUMBER and SERIAL NUMBER may be found on the PRODUCT ID LABEL located on the front of the VPC product on the center face of lower portion of the unit.

Stay in Touch!
Scan the QR Code at right
for company information
and product updates



Our Address:

VRG Controls, LLC
467 Ridge Road
Highland Park, Illinois USA
www.vrgcontrols.com
eMail: Sales@VRGControls.com

We recommend that you record the MODEL NUMBER and SERIAL NUMBER of all VRG Products installed at each application location in the table below for future reference.

Installed Product Identification Log

Item	Tag	Model Number	Serial Number
1			
2			
3			
4			
5			
6			
7			
8			
Example	Run 1 Monitor Regulator	RP-700-SN-CS	0912123R

Product ID Label



Applicable Models:

This Instruction Manual applies to the following RP Series Regulator Pilots. To confirm suitability for additional models and/or components, please contact VRG Controls or view us online at www.vrgcontrols.com.

RP-225-SN-CS

RP-700-SN-OS

RP-1500-SN-CS

RP-700-SN-CS

RP-700-SN-CS-HP

Description:

RP Series Regulator Pilots are reversible pressure control regulator devices designed for use in conjunction with pilot-operated regulator bodies. They can be used for pressure reducing, backpressure or relief type applications. The RP Series Regulator Pilots are designed for gas applications and provide better performance than other standard-issue regulator pilots.

RP Series Regulator Pilots are available with three (3) differently sized sensing diaphragms that are suited for different applications based upon the maximum sensing pressure applied and the desired setpoint pressure to be achieved. See Control Spring Specifications Table for additional information.

RP Series Regulator Pilots utilize an internal seat & nozzle internal loading configuration as noted by the characters “SN” in the model number derivation. Internal nozzles are available in 3/32, 1/8, and 3/16 inch diameter. The internal nozzles may be interchanged to achieve required performance based upon application criteria. Standard issue internal nozzle is 3/32” diameter which is suitable for typical pipeline applications, powerplants, and in conjunction with Mooney or Grove regulators. For use with Red Ox regulators, a 1/8” diameter nozzle should be used. For operations requiring fast operations such as asphalt plants, a 3/16” diameter nozzle should be used.

RP Series Regulator Pilots are available with two (2) different sensing chamber configurations. The “CS” closed spring sensing chamber design minimizes forces applied to the pilot internal mechanism and exhibits the optimum control accuracy, sensitivity and stability. Furthermore the “CS” closed spring sensing chamber encapsulates the control spring within the process media eliminating exposure to the local atmosphere and protecting it from corrosive environments. The “OS” open spring sensing chamber provides high performance control accuracy at a reduced price with fewer parts.

RP Series Pilots parts are interchangeable across model numbers and even across some product series in the VRG products lines. This interchangeability facilitates understanding of maintenance and operation and may benefit operators in the field in the event that parts may be needed on an immediate basis for conversion of models and/or repair. All RP Series Pilots feature body construction with VRG Military Grade Aluminum Alloy with “Stealth System” Corrosion Protection materials and 316 Stainless Steel to ensure durability and long life in even the most corrosive environments.

The RP Series Regulator Pilot features a manifolded Adjustable Orifice installed on the INLET side of the device. Three (3) different sizes of Adjustable Orifices are available (S, M, and L) to adapt to different operating scenarios and ensure optimal performance. Use M orifice and 1/8” nozzle for Red Ox applications. Use S orifice and 3/32” nozzle for Mooney and Grove power plant applications. Use S orifice and 1/8” nozzle for Mooney and Grove pipeline applications.

RP Pilots are available in two (2) different Actions: Normally Open (NO) & Normally Closed (NC). Normally Open (NO) is the standard issue product from VRG Controls and is commonly utilized for pressure reduction, while Normally Closed (NC) is used for backpressure control or as a safety relief valve. Reference the “RP Model Number Identification Label” on the body of the RP Regulator Pilot to confirm the Action of the pilot. Note that all RP Regulator Pilots may be field converted from Normally Open (NO) to Normally Closed (NC) and vice versa without the need for any additional parts. If an RP unit action is changed, we recommend that you obtain a new “RP Model Number Identification Label” in order to display the proper action.

Installation:**ATTENTION:**

Personal injury, damage, or explosion due to leakage of accumulated gas, or rupture of pressurized components could result if this pilot is overpressured or is installed where operating parameters could exceed the design limits as indicated in this manual, or where parameters exceed the ratings of the regulator body, adjacent piping or piping components & fittings. Verify the pressure limitations of pilot and the regulator on which it is installed to ensure neither device is overpressured. To avoid injury or damage to property, incorporate relief valves or pressure limiting devices to prevent operating parameters from exceeding required limits. Reference U.S. code of Federal Regulations, by the National Fire Codes of the National Fire Protection Association, or by other applicable codes or codes mandated by the operating company as needed.

WARNING

Regulator Pilots and Pilot Operated Regulators installed in enclosed or confined spaces should be provided with adequate ventilation to prevent the potential of gas accumulation from leakage or venting. Leakage and vent gas can accumulate causing property damage, severe injury or death. Atmospheric vent ports should be vented to a safe area away from air intakes, or any hazardous location.

PERSONNEL: Installation of RP Series Regulator Pilots and other manufacture's Pilot Operated Regulator Bodies should be performed by qualified personnel that are familiar with high pressure natural gas piping and regulator technologies.

INSPECTION: Inspect the RP Series Pilot for damage that might have occurred in shipping and handling. Do NOT use any product that has any remote semblance of damage. Care should also be taken to ensure that no damage exists on previously installed products that may have been installed at previous locations. If the origin or operational capability of any product is suspect or unknown, we recommend confirmation of fitness for service by a qualified technician or by VRG Controls.

ACTION: Inspect the RP Model Number Identification Label AND the Body of the RP Series Pilot to ensure that the unit has the appropriate ACTION for the desired application. Figures XX and Table XX provide necessary information to confirm RP Series Pilot Action.

INSTALLATION ORIENTATION: RP Series Regulator Pilots may be installed in any orientation. However, for optimum results and ease of maintenance, it is typically recommended to install RP Series Pilots in a vertical orientation with the RP Series Setpoint Adjustment Screw pointing upward.

PILOT MOUNTING: The RP Series Pilot may be installed utilizing a convenient mounting bracket available from VRG Controls. The RP Pilot may be wall mounted or 2.0 in pipe mounted.

PIPING: Appropriate pipe thread seal tape should be applied to all fittings installed on the RP Pilot. Use of pipe dope is also encouraged to minimize potential for galling or damage to threaded connections. All threaded connection on the RP Pilot are ¼ in FNPT.

PILOT SUPPLY LINES: 3/8 in. stainless steel tubing should be utilized to make connections to the RP Series Pilot. The INLET connection should be made with restrictions in the piping components. In the event that an isolation valve is installed on the INLET connection, it should be a full-opening type, without restriction.

FILTRATION: Most gas pipeline applications do not require a filter on the INLET connection. If the application may exhibit dirty gas, an appropriate filter should be applied upstream of the INLET connection to prevent clogging of the ADJUSTABLE ORIFICE. The filter should be application appropriate with adequate capacity with filtration to 10µ.

PILOT DISCHARGE (OUT): 3/8 in stainless steel tubing or ¼ in diameter threaded, non-restricted connections should be utilized to make connections to the RP Series Pilot. The OUT connection should be made with restrictions in the piping components. In the event that an isolation valve is installed in the OUT connection, it should be a full-opening type without restriction.

PILOT GAS PRE-HEATERS: Pilot INLET gas may be heated to prevent excessive refrigeration effects and potential formation of ice or hydrates in the system. Pilot INLET gas heaters should be connected after the pilot filter upstream of the INLET port. Note that Pilot pre-heaters are NOT REQUIRED and may be considered per application when large pressure drops result in severe refrigeration effects.

SENSING LINES: Sensing Lines should be run from the Sensing Port of the RP Series Regulator Pilot to a point roughly 10 pipe diameters from the outlet of the pilot-operated regulator body. See table below for recommended piping configurations for Sensing Lines. Reduce as necessary to connect to the ¼ in FNPT ports on the RP Series Regulator Pilot. The Sensing Line connection should avoid turbulent areas (valves, reducers, and elbows) and should have a full bore opening to the pipe. Isolation valves are typically recommended on the Sensing Line(s) and should be non-restricted, full opening type.

Table 1.0 – Recommended Sensing Line Configuration for RP Series Pilots

Desired Setpoint Pressure		
in. WC ≤ SETPOINT < 2.0 psig	2.0 psig ≤ SETPOINT < 5.0 psig	5.0 psig ≤ SETPOINT
½ in Pipe (Min.)	½ in Seamless SS Tubing	¾ in Seamless SS Tubing

Maintenance

Regulator and control device parts utilized in gas regulation applications are subject to normal wear and should be inspected and replaced as necessary. The frequency of inspection and replacement of parts depends on severity of service conditions and/or the requirements of local, state, federal regulations. You should consult your company standards and regulations to determine protocol for maintenance on your equipment. It is critical to ensure that the RP Model Number Identification Labels, RP Spring Control Range Labels, and other applicable labels are updated and maintained to ensure legibility and accurately reflect the operation limitations of the device.

WARNING



Before removal, disassembly, or initiating maintenance ensure that the RP Series Regulator Pilot and the Pilot-Operated Regulator on which it is installed have been isolated from the process. All pressurized gas must be safely vented from the RP and Regulator System. Failure to relieve all pressure from the system may result in property damage, severe injury or death.

Applications:

The RP Series Regulator Pilot is designed to provide self-contained pressure control when incorporated with pilot-operated regulators. The system utilizes pressurized natural gas or from the pipeline to operate and can address a number of common pipeline pressure control applications. Contact VRG Controls for assistance with your application.

- **Primary Pressure Control (Active)**
- **Overpressure Protection (Monitor)**
- **Overpressure Protection (Relief)**
- **Underpressure Protection (Standby)**
- **Backpressure Control**
- **Two-Stage Pressure Control**
- **Power Plant Fuel Gas Feed**

RP Series Regulator Pilot Technical Specifications

RP Series	RP-SN-CS	RP-SN-OS
Type	Regulator Pilot	
Internal Valve Logic	Seat & Nozzle (SN)	
Spring Chamber Type	Closed Spring (CS)	Open Spring (OS)
Output	Single, Variable	
Available Action	Normally Open (NO), Normally Closed (NC)	
Setpoint Range	1.25 - 1500 psig (9.0 - 10342 kPa)	9 - 700 psig (62 - 4826 kPa)
Temperature Range	-20F to 160F (-29C to 71C)	
Pneumatic		
Supply Gas Quality	Dry, Filtered @ 10µ Natural Gas	
Max Inlet Pressure	225: 1500 psig 700: 700 psig 700-HP: 1500 psig 1500: 1500 psig	700: 700 psig
Max Outlet Pressure	225: 700 psig 700: 700 psig 700-HP: 1500 psig 1500: 1500 psig	700: 700 psig
Max Differential Pressure	225: 1500 psig 700: 700 psig 700-HP: 1500 psig 1500: 1500 psig	700: 700 psig
Max Sensing Pressure	225: 225 psig 700: 700 psig 700-HP: 700 psig 1500: 1500 psig	700: 700 psig
Connections	All ports 1/4" FNPT	
Available Nozzles*	3/32", 1/8", 3/16"	
Available Orifice	Small (S), Medium (M), Large (L)	
Construction		
External Parts	VRG Military Grade Aluminum Alloy with "Stealth System" Corrosion Protection 316 SS – Optional Construction	
Internal Parts	All internal parts 316SS	
Diaphragms	High Performance Nylon Reinforced Buna-N, VITON optional	
O-rings	Buna-N, VITON optional	
Control Springs	Painted Alloy Steel	
Gauges	2.5 in. Liquid-filled SS Case & Body	
Weight	11 lbs. (5.0 kg.)	10 lbs. (4.5kg)
Dimensions	12 in X 7.5 in X 4.0 in (305 mm X 191 mm X 102 mm)	13.5 in X 7.5 in X 4.0 in (343 mm X 191 mm X 102 mm)
Application Guide		
Pressure Reducing / Monitor (NO)	Optimal	Very Good
Relief / Backpressure (NC)	Optimal	Very Good
Boiler Power Plant	Optimal	N/A
Asphalt Plant	Optimal	N/A
Duct Burner Control	Optimal	N/A
Liquid Pressure Control	Optimal	Very Good
Performance Guide		
Sulfur Formation	Sulfur Resistant	
Flow Capacity	High Capacity	
Control Accuracy	Ultimate Accuracy	Very Good Accuracy

*Special order 1/4" nozzle available for asphalt plants, contact VRG Controls for more info

Model Number Explanation

BASE MODEL		PRESSURE SERIES		INTERNAL VALVE LOGIC		SPRING CHAMBER TYPE		NORMAL STATE		HIGH PRESSURE	
RP	Regulator Pilot	225	225 psig Max Sensing	SN	Seat & Nozzle	OS	Open Spring	NO	Normally Open	HP	High Pressure Model
		700	700 psig Max Sensing			CS	Closed Spring	NC	Normally Closed		
		1500	1500 psig Max Sensing								

Example: RP-700-SN-CS-NC-HP denotes a high pressure Regulator Pilot rated to 700 psig Sensing with a seat & nozzle internal assembly that is normally closed. The high pressure suffix (-HP) is only applied to 700 models. It increases the maximum inlet/outlet pressure to 1500 psig, while the standard model has a maximum inlet/outlet pressure of 700 psig.

RP Model Number Identification Label:

RP Spring Control Range Label:

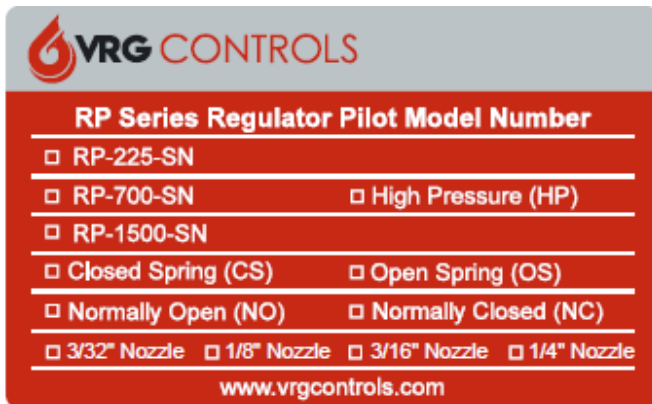

VRG CONTROLS

RP Series Regulator Pilot Model Number

- RP-225-SN
- RP-700-SN High Pressure (HP)
- RP-1500-SN
- Closed Spring (CS) Open Spring (OS)
- Normally Open (NO) Normally Closed (NC)
- 3/32" Nozzle 1/8" Nozzle 3/16" Nozzle 1/4" Nozzle

www.vrgcontrols.com

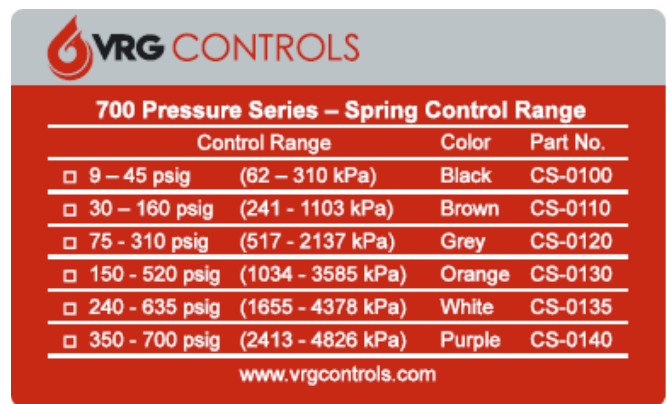

VRG CONTROLS

700 Pressure Series – Spring Control Range

Control Range	Color	Part No.
<input type="checkbox"/> 9 – 45 psig (62 – 310 kPa)	Black	CS-0100
<input type="checkbox"/> 30 – 160 psig (241 - 1103 kPa)	Brown	CS-0110
<input type="checkbox"/> 75 - 310 psig (517 - 2137 kPa)	Grey	CS-0120
<input type="checkbox"/> 150 - 520 psig (1034 - 3585 kPa)	Orange	CS-0130
<input type="checkbox"/> 240 - 635 psig (1655 - 4378 kPa)	White	CS-0135
<input type="checkbox"/> 350 - 700 psig (2413 - 4826 kPa)	Purple	CS-0140

www.vrgcontrols.com

Control Spring Specifications

RP Model	Control Range	Spring Color	Setpoint Change per Revolution	Setpoint Accuracy	Control Spring Part Number
<u>Models:</u> RP-225-SN-CS	1.25-15 psig 9-103 kPa	Black	0.8 psig 5.5 kPa	±0.1 psig ±0.7 kPa	CS-0100
	8-53 psig 55-365 kPa	Brown	3.1 psig 21.4 kPa	±0.2 psig ±0.7 kPa	CS-0110
	16-100 psig 110-689 kPa	Grey	8 psig 55 kPa	±0.3 psig ±1.0 kPa	CS-0120
	40-170 psig 276-1172 kPa	Orange	20 psig 139 kPa	±0.4 psig ±2.6 kPa	CS-0130
	65-205 psig 448-1413 kPa	White	32 psig 222 kPa	±0.6 psig ±4.2 kPa	CS-0135
	100-225 psig 689-1551 kPa	Purple	44 psig 305 kPa	±0.8 psig ±5.6 kPa	CS-0140
<u>Models:</u> RP-700-SN-CS RP-700-SN-OS RP-700-SN-OS-HP	9-45 psig 62-310 kPa	Black	2.4 psig 17 kPa	±0.4 psig ±2.4 kPa	CS-0100
	35-160 psig 241-1103 kPa	Brown	10.6 psig 3 kPa	±0.5 psig ±3.4 kPa	CS-0110
	75-310 psig 517-2137 kPa	Grey	25.4 psig 175 kPa	±1.1 psig ±7.7 kPa	CS-0120
	150-520 psig 1034-3585 kPa	Orange	61.4 psig 423 kPa	±2.7 psig ±18.6 kPa	CS-0130
	240-635 psig 1586-4447 kPa	White	100 psig 687 kPa	±4.4 psig ±30.3 kPa	CS-0135
	350-700 psig 2413-4826 kPa	Purple	134 psig 926 kPa	±5.8 psig ±40.0 kPa	CS-0140
<u>Models:</u> RP-1500-SN-CS	30-90 psig 207-620 kPa	Black	4.9 psig 34 kPa	±3.5 psig ±24 kPa	CS-0100
	50-335 psig 345-2309 kPa	Brown	21.7 psig 149 kPa	±3.5 psig ±24 kPa	CS-0110
	100-640 psig 689-4412 kPa	Grey	52.3 psig 361 kPa	±3.5 psig ±24 kPa	CS-0120
	265-1070 psig 1827-7377 kPa	Orange	126 psig 870 kPa	±5.5 psig ±38 kPa	CS-0130
	400-1300 psig 2758-8962 kPa	White	204 psig 870 kPa	±9.1 psig ±63 kPa	CS-0135
	625-1500 psig 4309-10341 kPa	Purple	276 psig 1904 kPa	±11.9 psig ±82 kPa	CS-0140

Flow Calculations

Critical Flow Equation:

$$Q_c = 312.9 \times (P_1 + 14.7) \times C_v \times \sqrt{\frac{1}{G \times (T + 460)}}$$

Where:

Variable	Description	Unit
Q_c	Critical Flow Across Inlet Orifice	Scfh
P₁	Supply Pressure	Psig
C_v	Flow Factor	--
G	Specific Gravity of Gas	--
T	Gas Temperature	°F

Flow Coefficient Tables (Cv)

Adjustable Orifice Flow Coefficients

Installed Orifice	Adjustable Orifice Setting							
	0	1	2	3	4	5	6	7
Standard	0.003	0.004	0.009	0.026	0.042	0.071	0.100	0.123
Medium (M)	0.042	0.045	0.062	0.089	.134	0.172	0.211	0.249
Large (L)	0.042	0.063	0.172	0.328	0.461	0.578	0.634	0.675

Lockup & Droop:

These quantities depend on inlet flowrate fluctuations, and increase as the regulator becomes more open. They can be assumed to be 2% of the maximum spring range value when the regulator is 100% open. For example, units with a grey 225 spring can be assumed to have .02 x 100 = 2 psig maximum lockup and droop, which occurs when the regulator is 100% open.

RPT Block Explanation

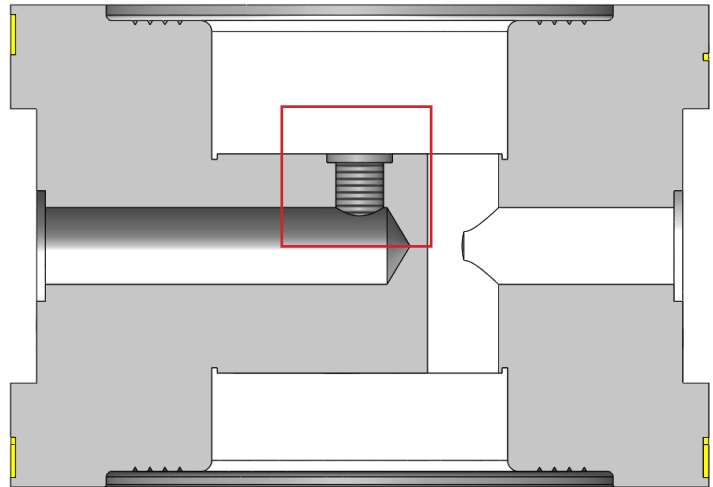
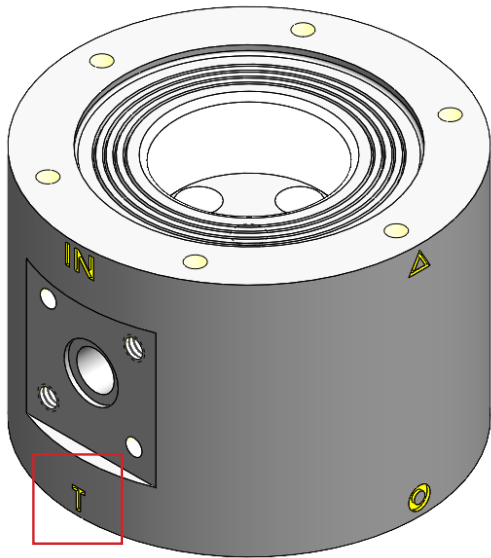

All RPT pilot blocks are inscribed with a T at the bottom of the IN and OUT ports to denote that they are threaded blocks. The blocks are machined with a 5/16-24 threaded hole that the nozzle is screwed into. Ensure that a #10 O-ring sits on the lip of the threaded hole prior to installing the nozzle. 3/32, 1/8, and 3/16" nozzles are all interchangeable for the RPT block.

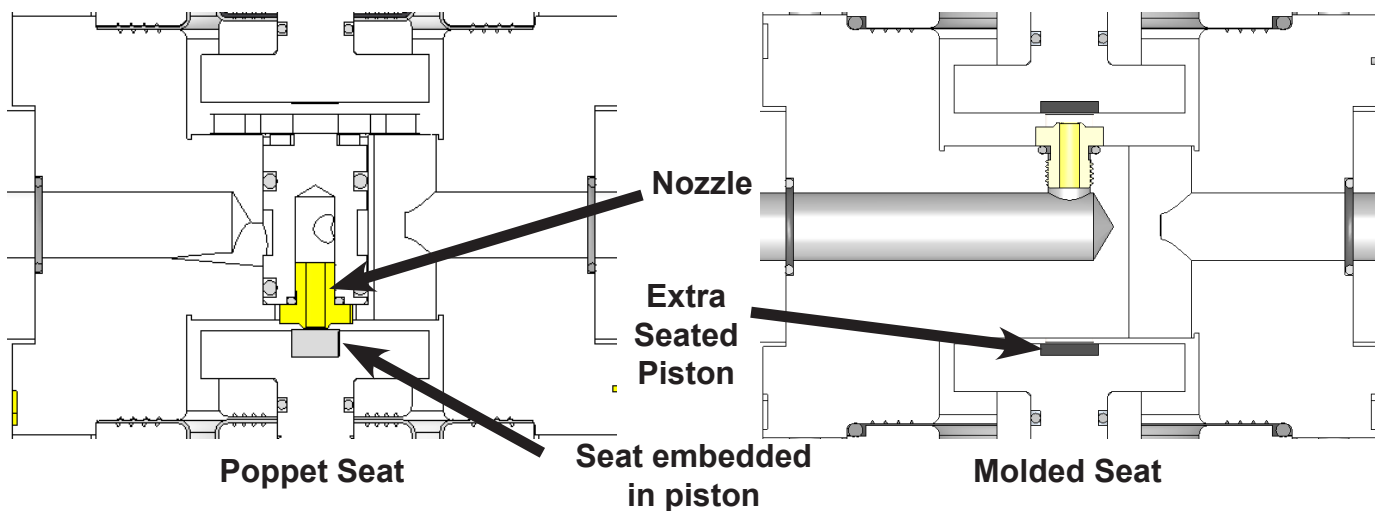

The seat and nozzle assembly is the mechanism that allows pressure control for the RP pilots. The seat is embedded in a piston that is raised or lowered depending on sensing pressure, either allowing more or less flow to pass through the pilot. The amount of flow passing through the pilot is proportional to the distance between the seat and nozzle. If sensing pressure is removed from the pilot and no flow passes through the pilot, the pilot is denoted as normally closed. If sensing pressure is removed from the pilot and the maximum amount of flow passes through the pilot, then the pilot is denoted as normally open. There are 2 styles of seat: poppet and molded. For high pressure applications (700-HP and 1500 pilots), the molded seat is used. These seats are not replacable, so an extra piston with seat is included in the assembly. All other applications use the poppet style seat, which is replacable.

Available Models

PA-0190: RP-225-SN-CS-NO
Repair Kit RK-0540

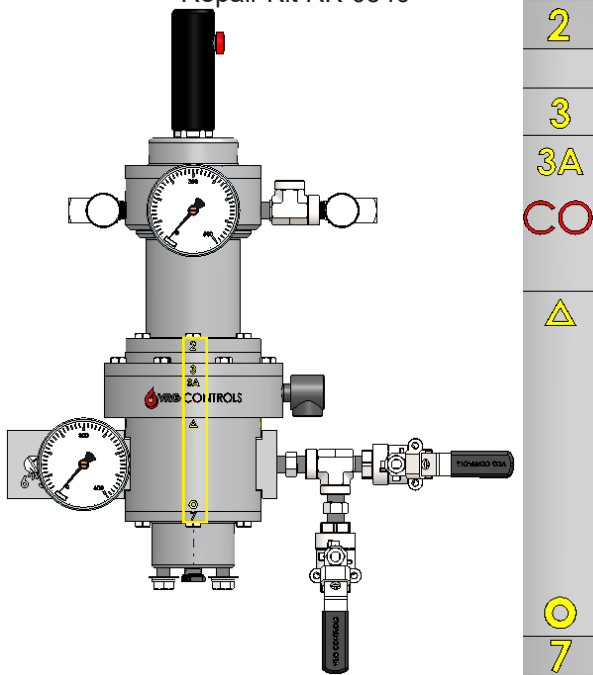

PA-0191: RP-225-SN-CS-NC
Repair Kit RK-0540

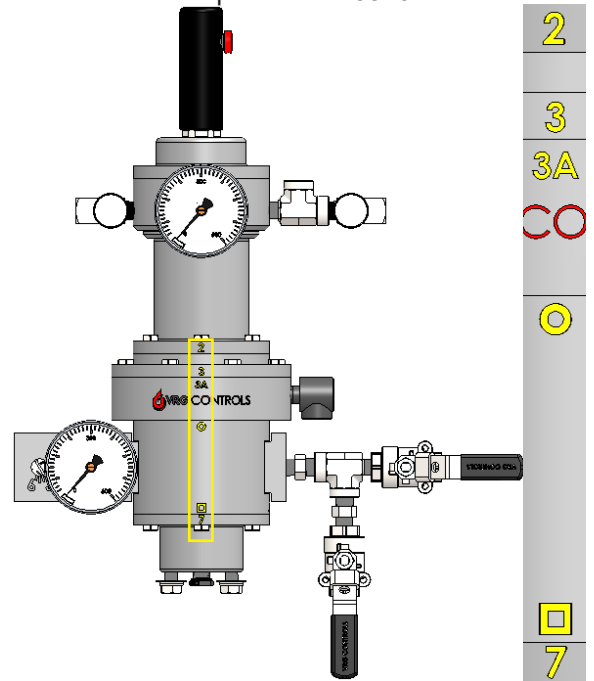

PA-0200: RP-700-SN-CS-NO
Repair Kit RK-0400

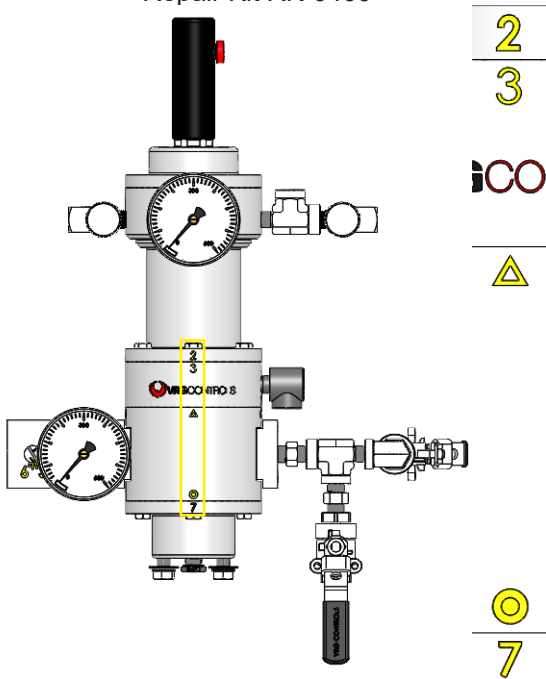

PA-0201: RP-700-SN-CS-NC
Repair Kit RK-0400

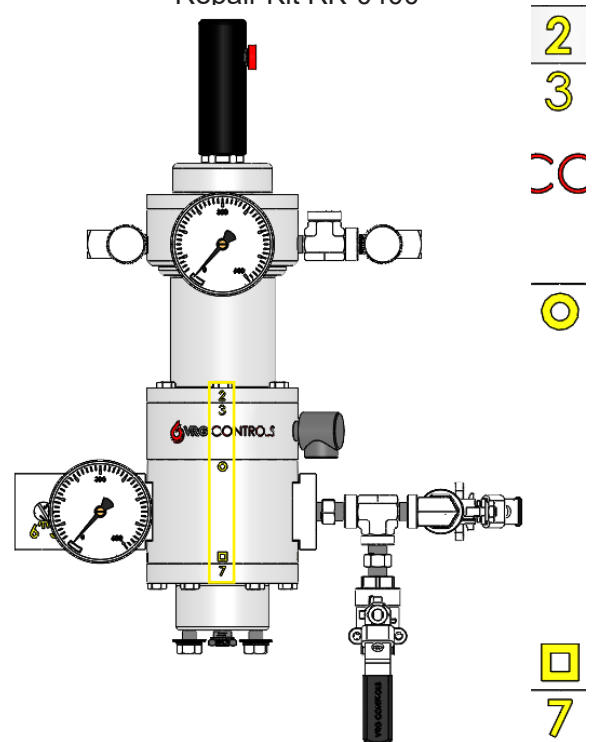

PA-0300: RP-700-SN-OS-NO
Repair Kit RK-0400

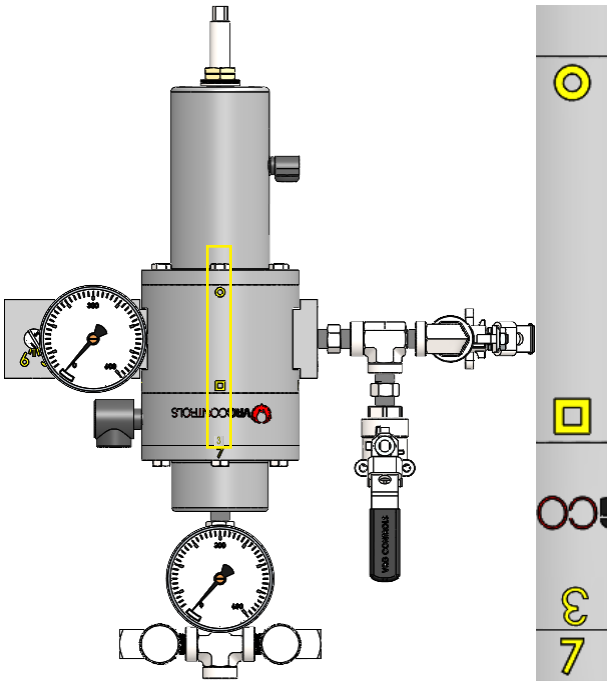

PA-0301: RP-700-SN-OS-NC
Repair Kit RK-0400

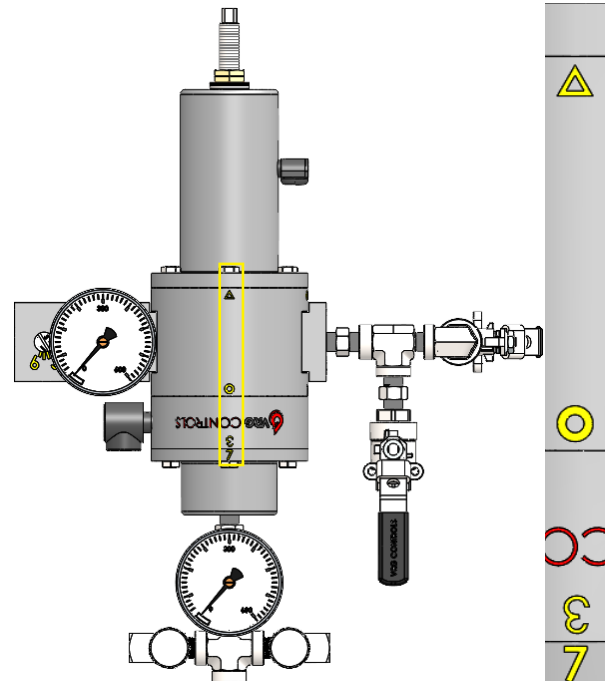

PA-0200-HP: RP-700-SN-CS-NO-HP
Repair Kit RK-0550

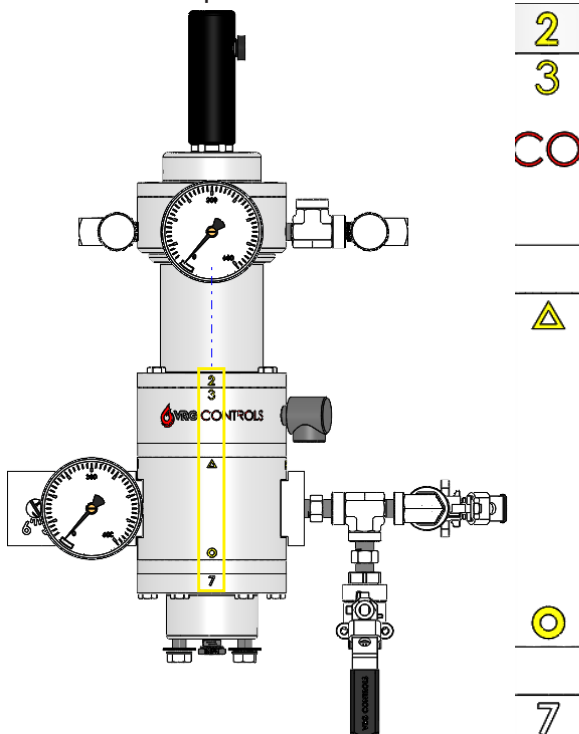

PA-0201-HP: RP-700-SN-CS-NC-HP
Repair Kit RK-0550

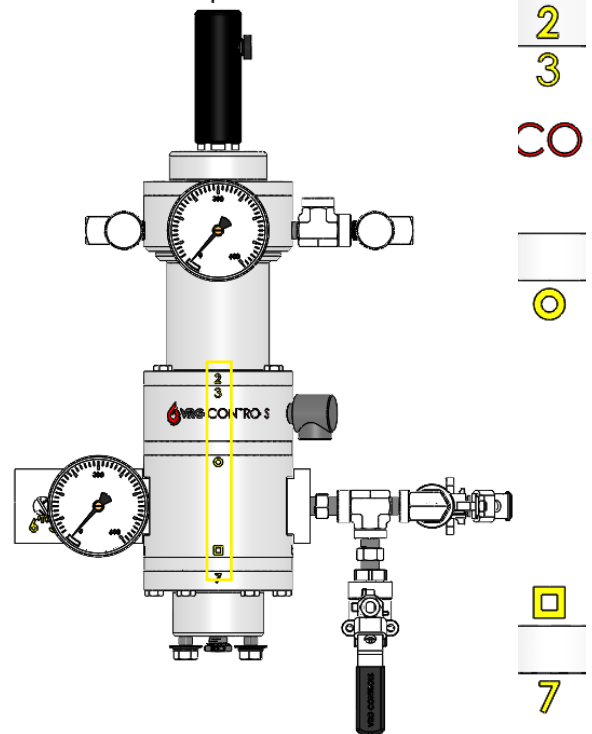

PA-0210: RP-1500-SN-CS-NO
Repair Kit RK-0550

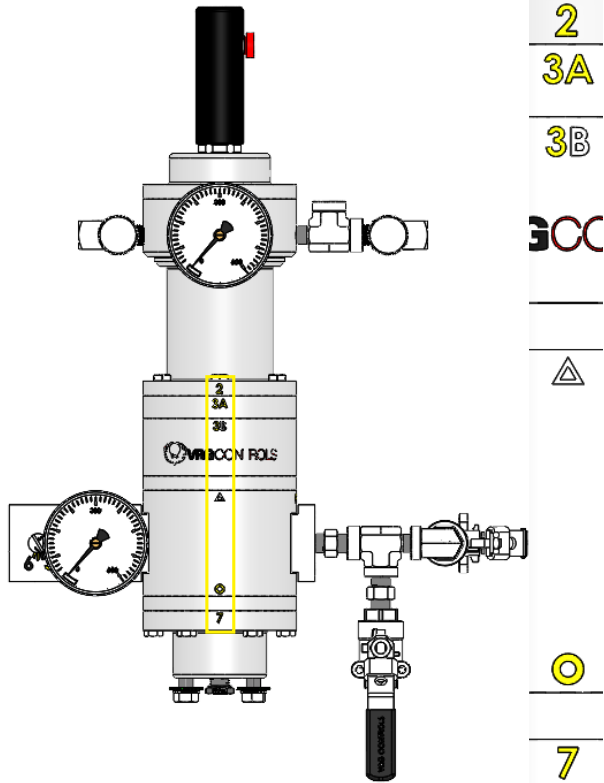

PA-0215: RP-1500-SN-CS-NC
Repair Kit RK-0550

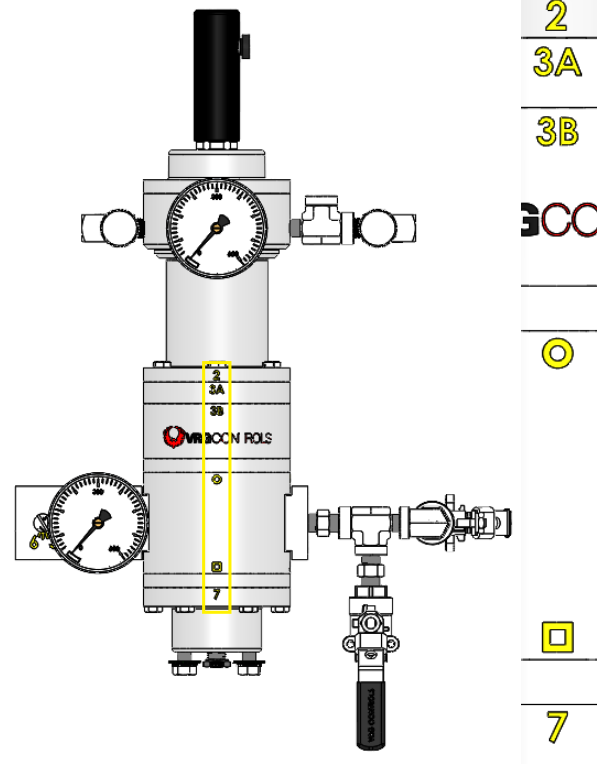

Repair Kits

RK-0540: RP-225-SN REPAIR KIT

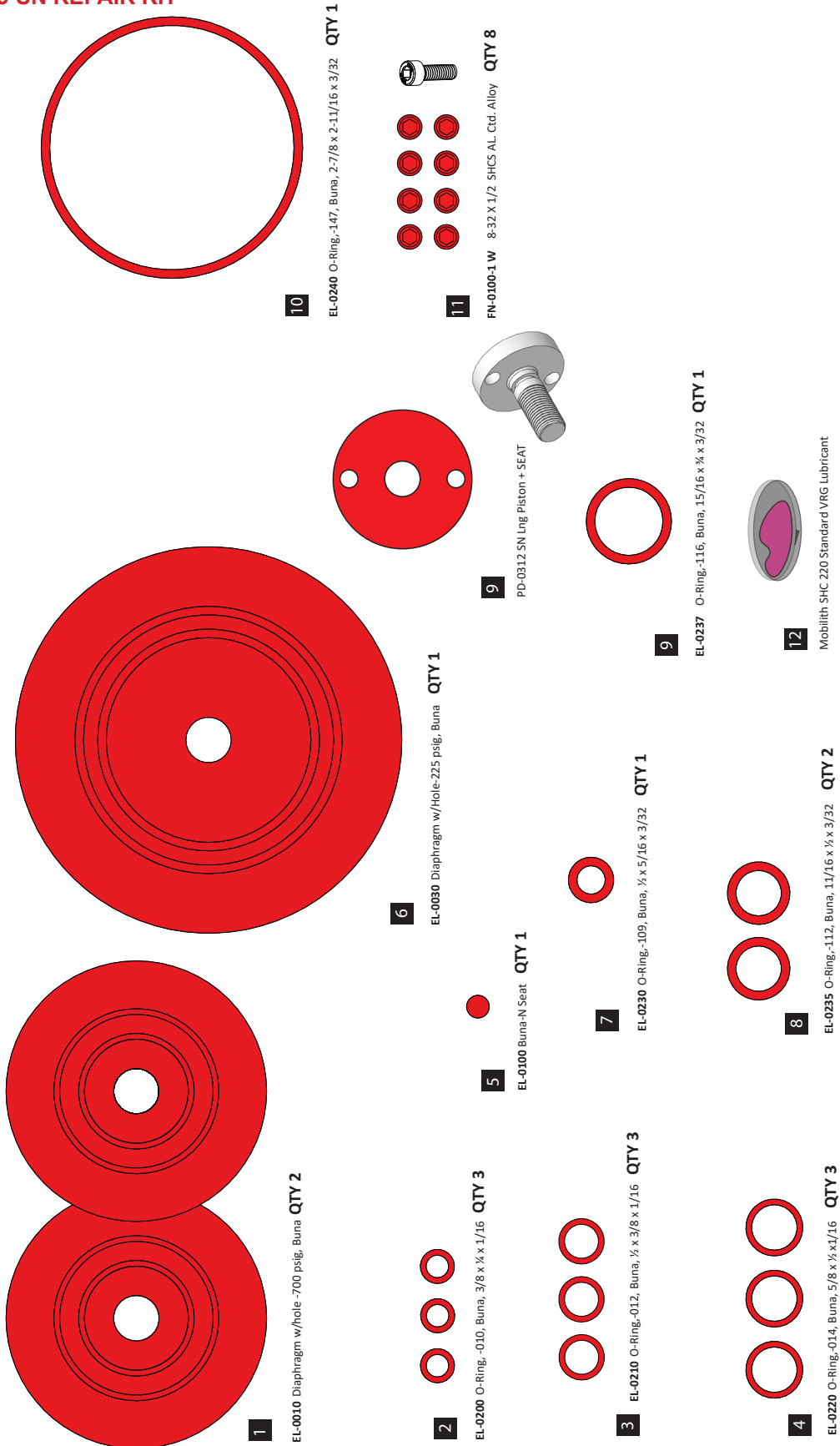

RK-0400: RP-700-SN REPAIR KIT

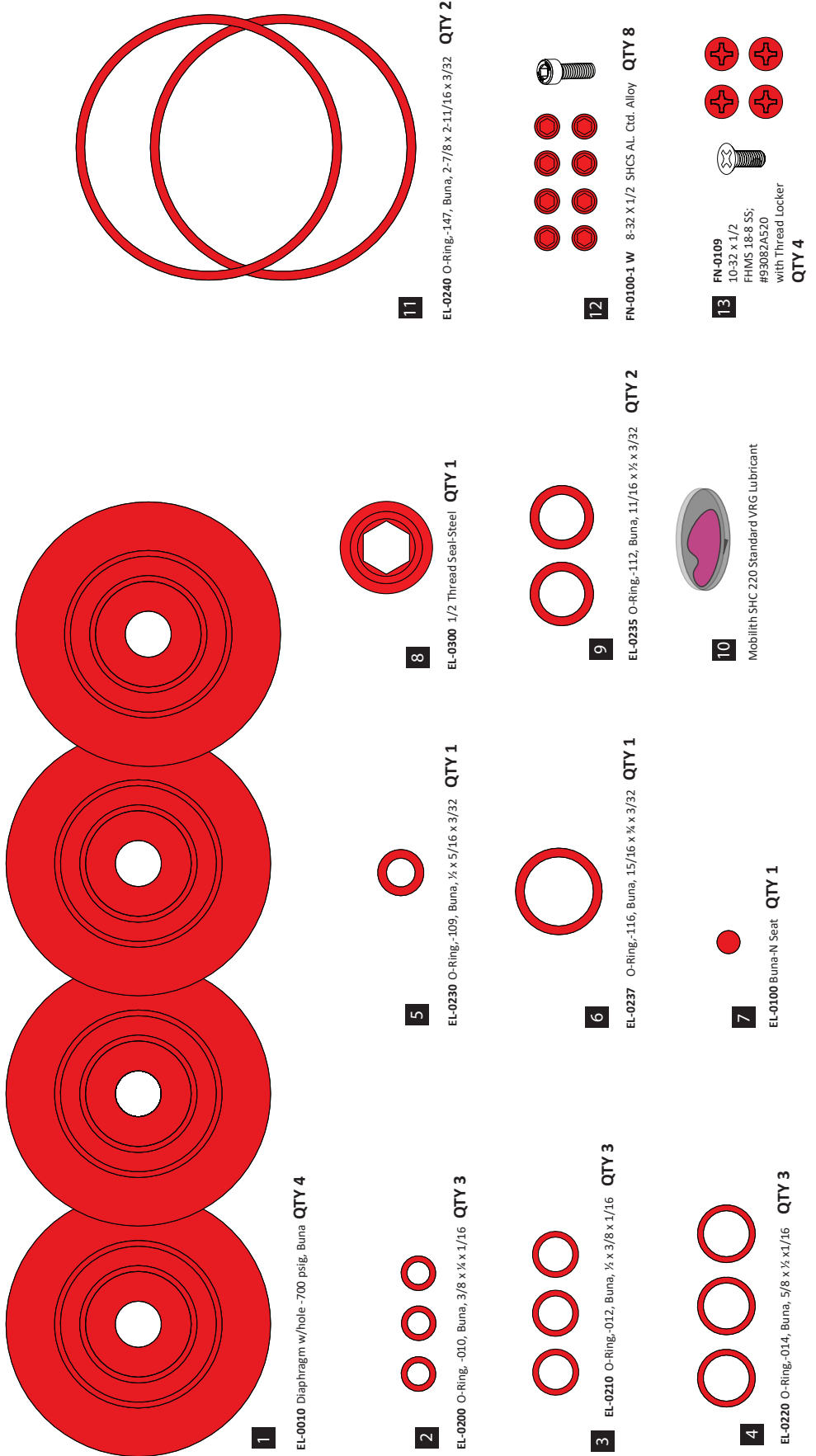

RK-0550: RP-700-HP-SN & RP-1500-SN REPAIR KIT

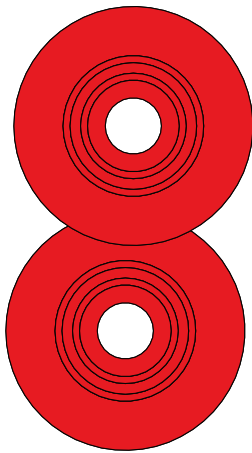

1 EL-0020 Diaphragm w/hole -1500 psig, Buna **QTY 2**



2 EL-0200 O-Ring, -010, Buna, 3/8 x 1/4 x 1/16 **QTY 2**



3 EL-0210 O-Ring, -012, Buna, 1/2 x 3/8 x 1/16 **QTY 3**



4 EL-0220 O-Ring, -014, Buna, 5/8 x 1/2 x 1/16 **QTY 2**



5 EL-0230 O-Ring, -109, Buna, 1/2 x 5/16 x 3/32 **QTY 1**

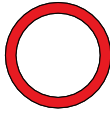

7 EL-0237 O-Ring, -116, Buna, 15/16 x 1/2 x 3/32 **QTY 1**

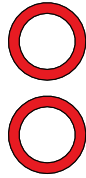

6 EL-0235 O-Ring, -112, Buna, 11/16 x 1/2 x 3/32 **QTY 2**



10 Mobilith SHC 220 Standard VRG Lubricant

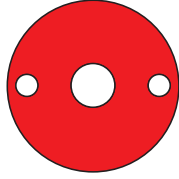

9 PD-0494 SN Lng Piston + SEAT

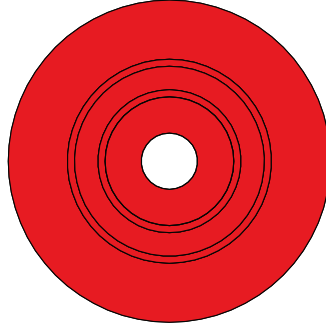

12 EL-0010 Diaphragm w/hole -700 psig, Buna **QTY 1**

RP Factory Quality Checklist

Date: _____

VRG Invoice Number: _____

Technician Name: _____ **Technician Signature:** _____

QC Name: _____ **QC Signature:** _____

Model Number: _____

Serial Number: _____

Customer: _____

Customer Tag: _____

Supply Pressure

Discharge Pressure

Orifice Setting _____

Procedure	Verified	Notes
Apply Maximum Sensing Pressure 30 min.	<input type="checkbox"/> VERIFY	
Adjust RP to Setpoint	<input type="checkbox"/> VERIFY	
Friction Test	<input type="checkbox"/> VERIFY	
Gage Check (if applicable)	<input type="checkbox"/> VERIFY	
Valve Leak Check	<input type="checkbox"/> VERIFY	
Assembly Leak Check	<input type="checkbox"/> VERIFY	
Seat Check	<input type="checkbox"/> VERIFY	
Sensitivity Check	<input type="checkbox"/> VERIFY	
Label Check	<input type="checkbox"/> VERIFY	

Notes:

Application Table of Contents

Description	Page
Downstream Pressure Control	20
Relief Valve	21
Backpressure Valve	22
2-Stage Cut with Monitor Override	23
Remote Setpoint Adjustment	24

Application 1: Downstream Pressure Control

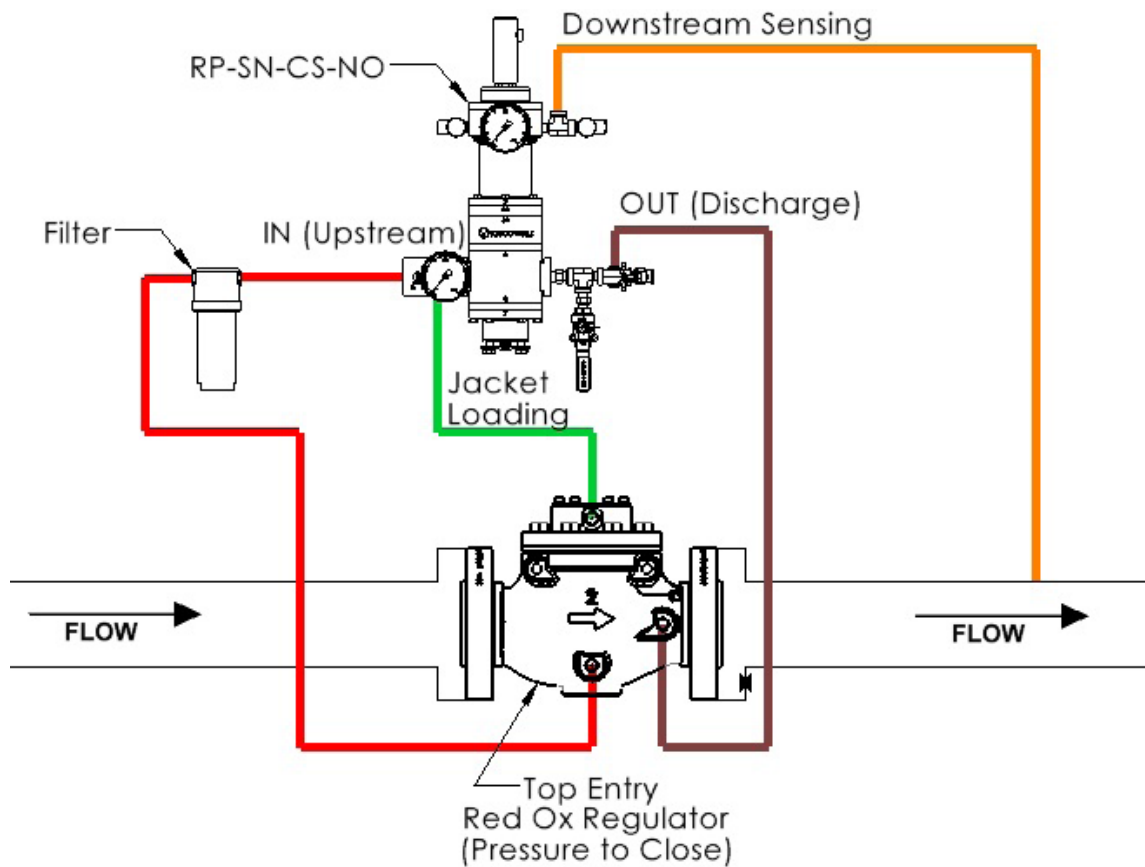

In this application, the RP is used to regulate line pressure based on downstream sensing. The pilot is normally open, meaning that the nozzle is pointed upward. Upon rising downstream pressure, the piston will lower and close off the nozzle. No flow will pass through the pilot, and all incoming pressure from the upstream side of the Red Ox regulator will be directed through the jacket port, to the loading side of the Red Ox. The Red Ox will begin to close, and downstream pressure will fall until setpoint is reached. In the case of falling downstream pressure, the piston will rise and more flow will pass through the pilot, to the downstream side of the Red Ox. Jacket pressure will fall, and the Red Ox regulator will open until RP setpoint is achieved.

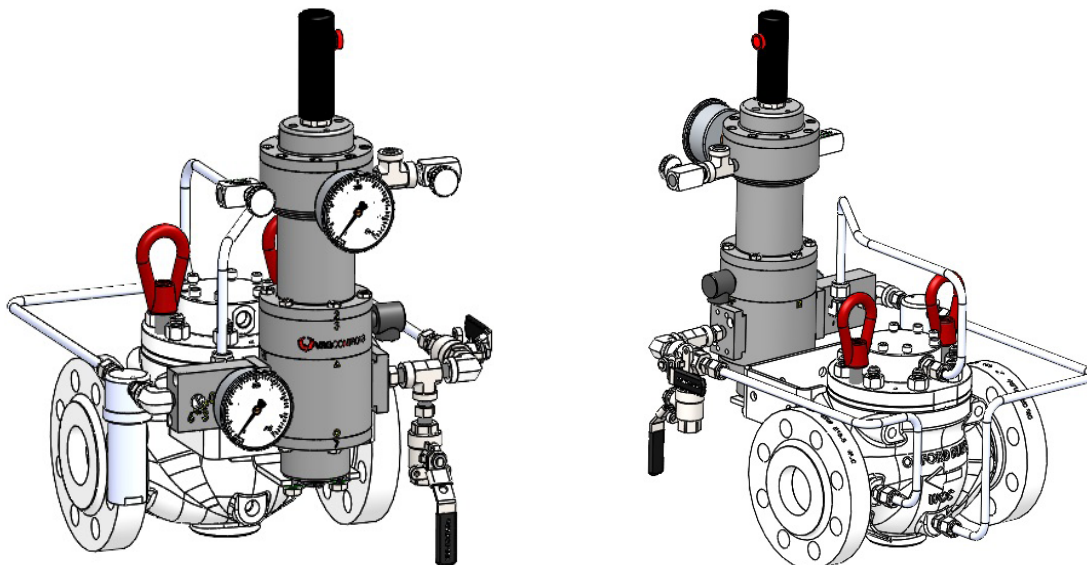

Application 2: Relief Valve

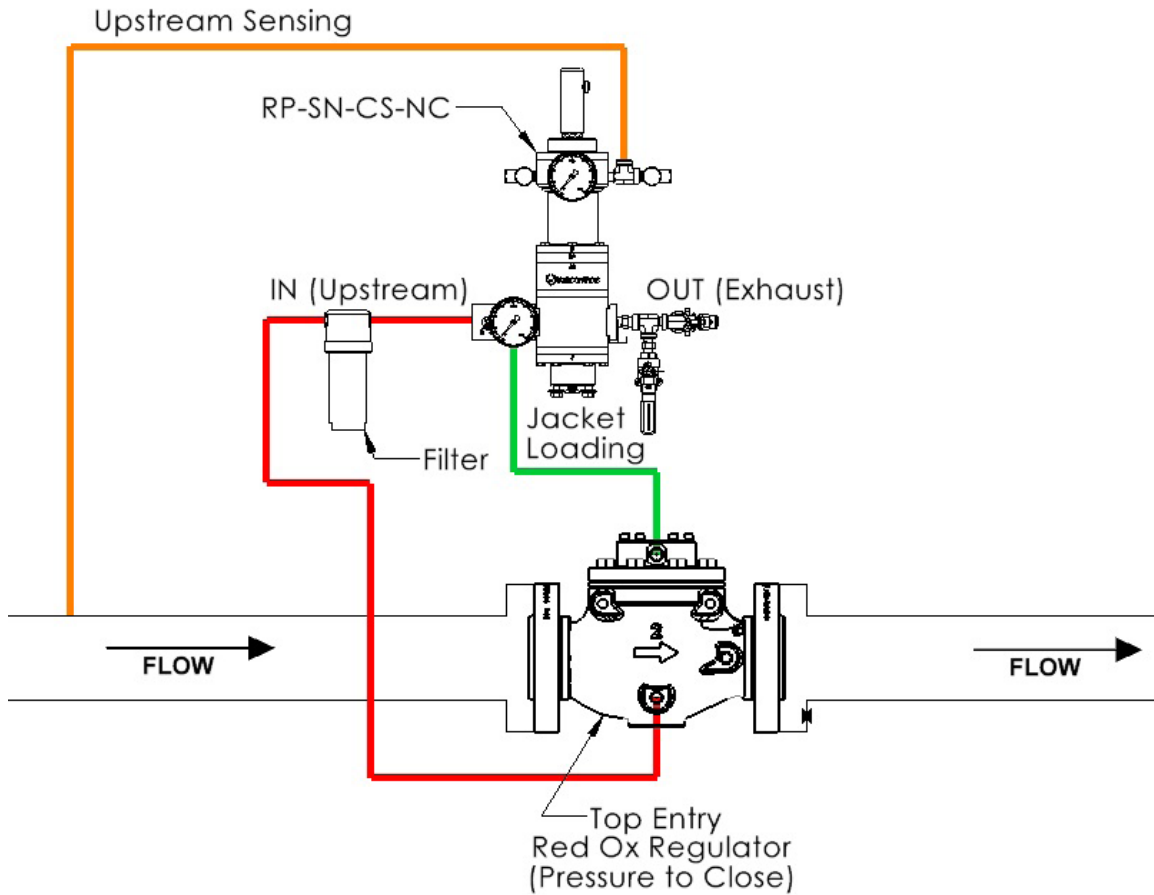

In this application, the RP is used to open the Red Ox regulator upon rising upstream pressure. The pilot is normally closed, so the nozzle is pointed downward. Rising upstream pressure will push the piston away from the nozzle, allowing flow to pass through the RP. Jacket pressure will reduce as flow goes through the RP and is exhausted, and the regulator will open to protect the line from overpressure.

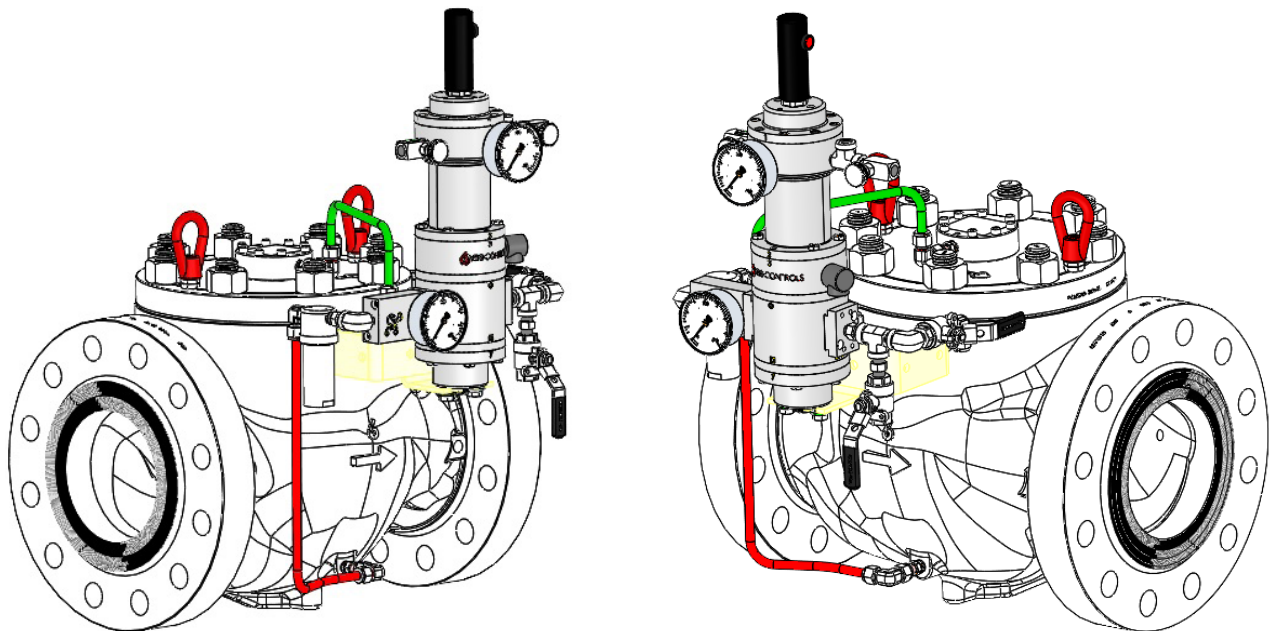

Application 3: Backpressure Valve

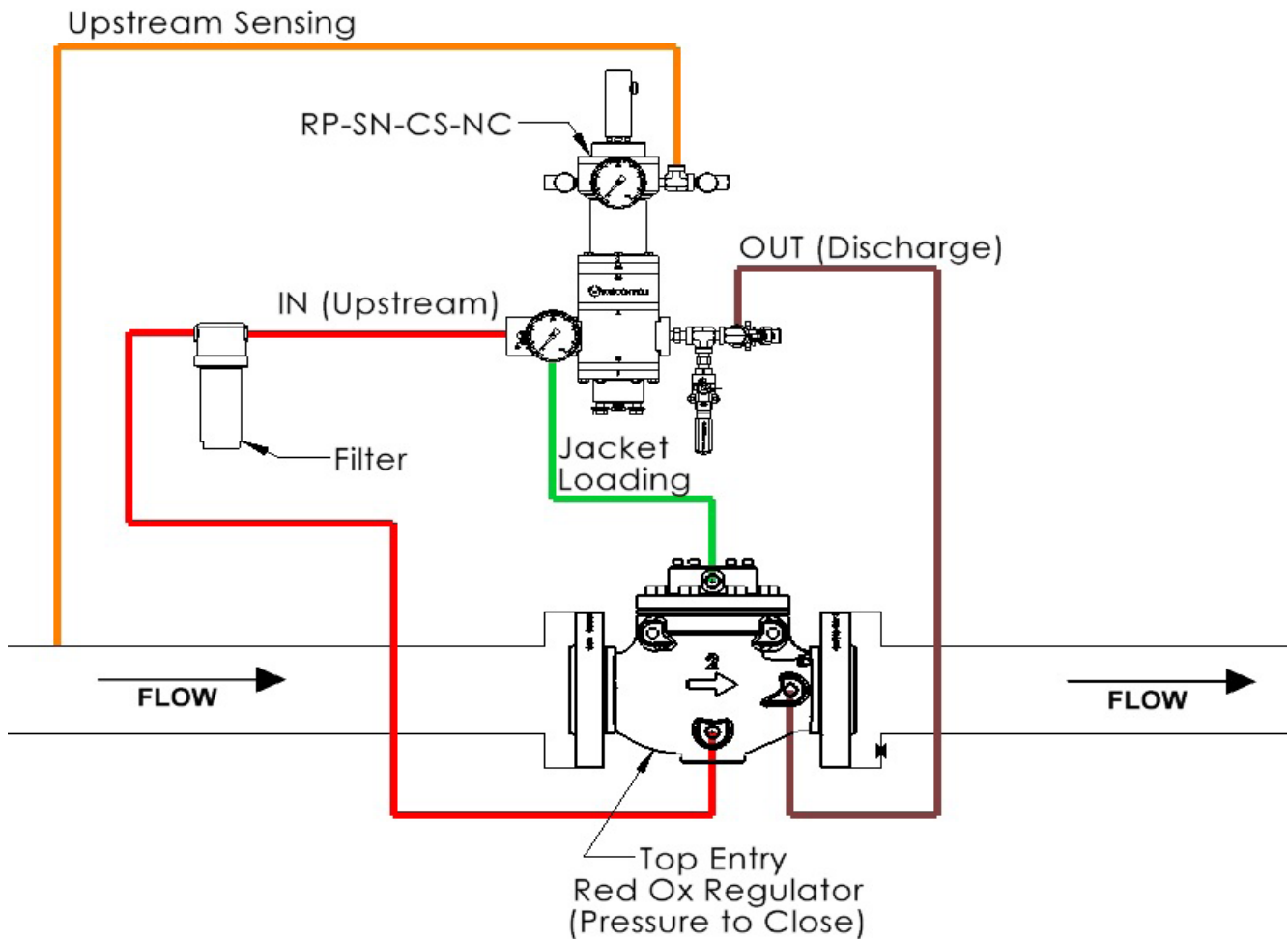

In this application, the RP is used to open the Red Ox regulator upon rising upstream pressure. The RP is normally closed, so the nozzle points downwards. Rising upstream pressure will push the piston away from the nozzle, opening the RP and reducing the pressure to jacket loading. The Red Ox regulator will then open, allowing an outlet to reduce backpressure within the line.

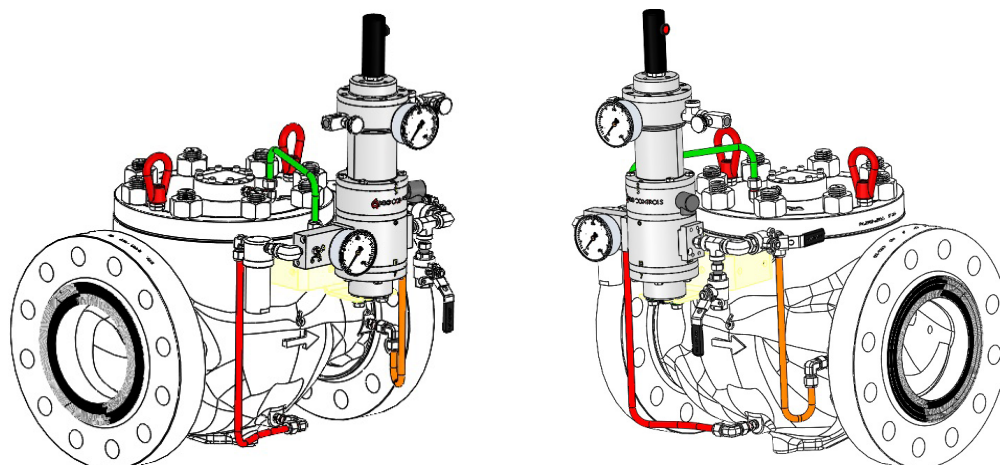

Application 4: 2-stage Cut with Monitor Override

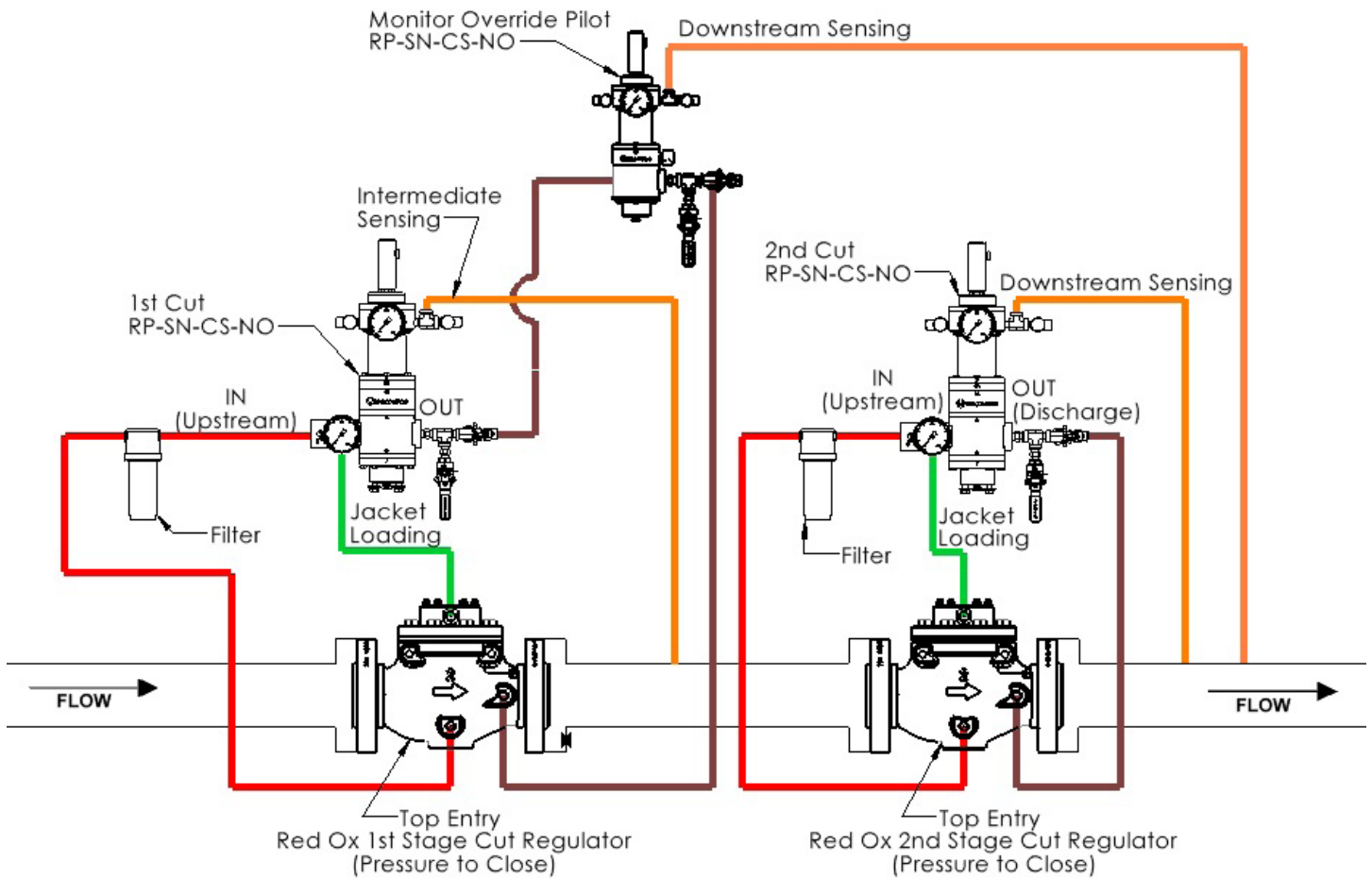

In this application, three RPs and two Red Ox regulators are used to make a 2-stage pressure cut with a monitor override for overpressure protection. All 3 RPs are normally open, so the nozzles point upward. Rising sensing pressure will lower the piston and close off the nozzle, restricting flow through the RP. Inlet pressure will be directed to jacket loading, and the regulator will close. The upstream RP will sense intermediate pressure between the 2 regulators, and the downstream RP will sense downstream pressure. This way, a large pressure cut can be dispersed between two devices to reduce extreme, sudden pressure cuts. The monitor setpoint will be higher than the 1st stage RP setpoint. Under normal operating conditions the monitor will be wide open. If downstream pressure rises above normal operating levels, the monitor will close, and flow into the 1st stage RP will be directed to jacket loading, closing the Red Ox regulator.

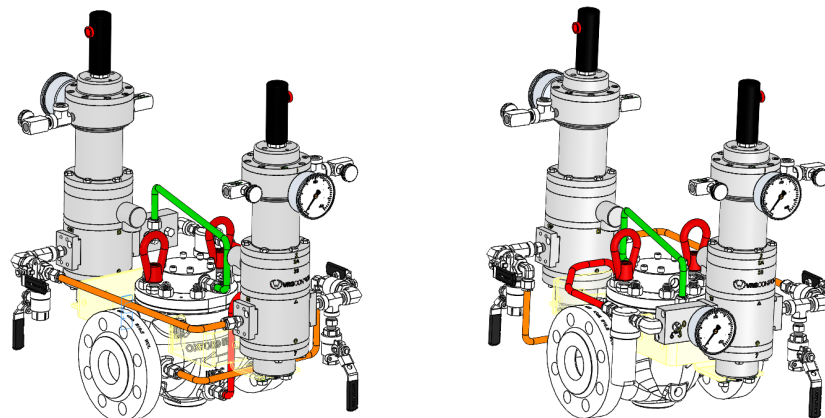

Application 5: Remote Setpoint Adjustment

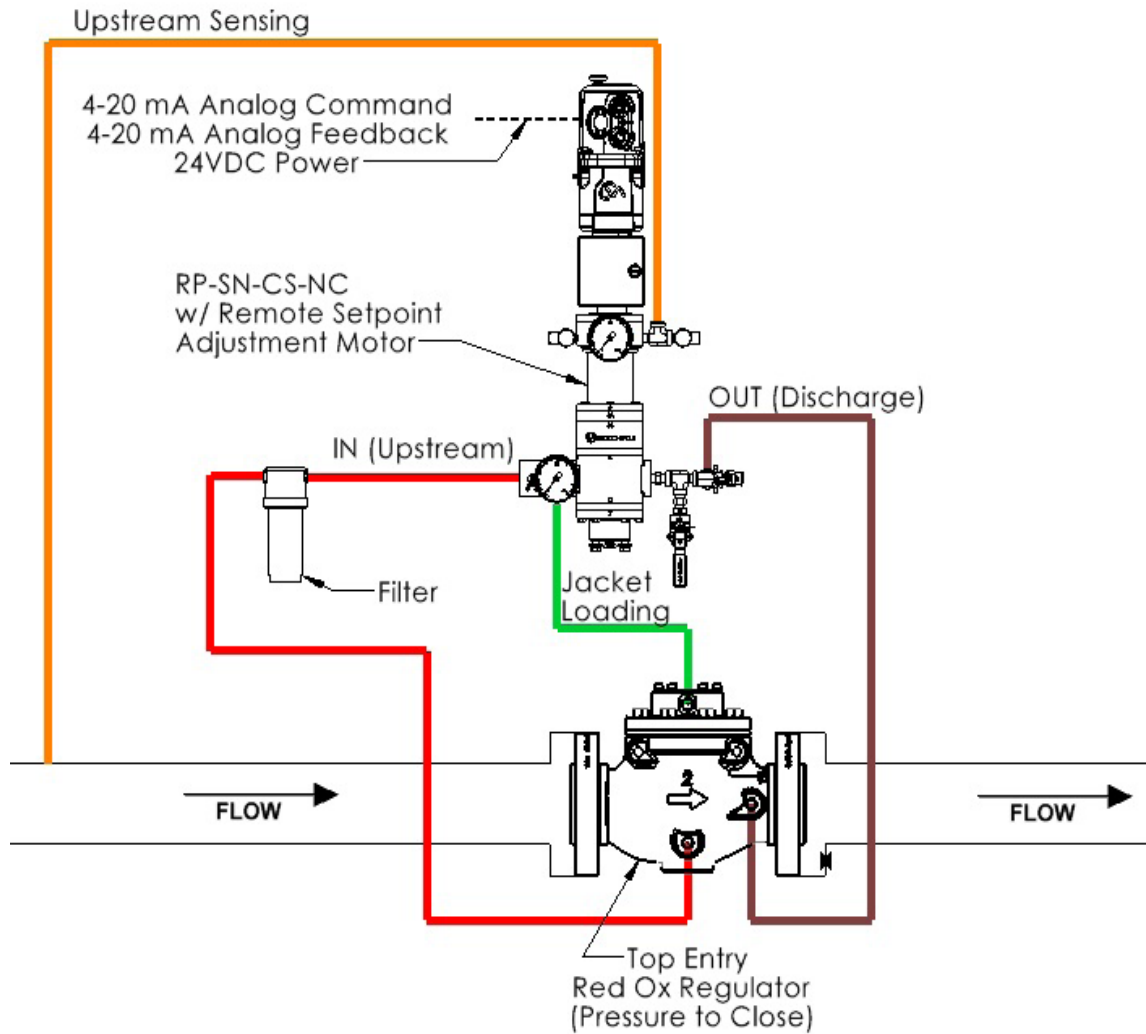

CLOSED SPRING RP Pilots may be mounted with a motor for remote setpoint adjustment. By supplying the motor with 24 VDC power and a 4-20 mA signal, setpoint may be remotely adjusted from an RTU building.

